

PEOPLE HAVE PRIORITY

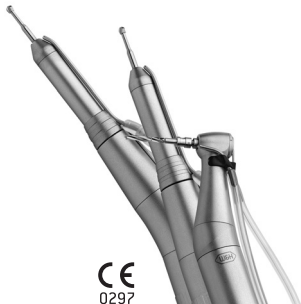

Instructions for use



CE
0297

Surgical

Handpieces S-9, S-10, S-11, SL-11, S-12
Contra-angles WS-56 E, WS-75 E/KM, WS-92 E/3

Contents

W&H Symbols	3
1. Introduction	4 – 5
2. Before use – Safety notes	6 – 8
3. Product description handpiece / contra-angle	9 – 12
4. Operation	13 – 23
Assembly / Removal (13–15), To change rotary instrument (16–22), Test run (23)	
5. Hygienic maintenance	24 – 46
General (24–25), Pre-disinfection (26), Disassemble (28–30), Manual cleaning (31–34), Manual disinfection (35), Mechanical cleaning and disinfection (36), Reassemble (37–40), Oil service (41–44), Sterilization (45–46)	
6. W&H Accessories	47
7. Technical data	48 – 49
Letter of indemnity	50
Authorized W&H service partner	51

W&H Symbols



WARNING!
(Risk of injury)



ATTENTION!
(to prevent
damage occurring)



General
explanations,
without risk to
persons or objects



Thermo washer
disinfectable



Sterilizable
up to the stated
temperature



Data Matrix Code for product
identification, e.g. in hygienic
maintenance process

For USA and Canada:

Caution ! Federal law restricts this device to sale by or on the order of a dentist, physician or any other practitioner licensed by the law of the State in which he or she practices to use or order the use of the device.

1. Introduction

Customer satisfaction is the main priority under the W&H quality policy. This W&H product has been developed, manufactured and subjected to final inspection according to legal regulations, quality norms and industry standards.

For your safety and the safety of your patients

Prior to initial use please read the Instructions for use. These explain how to use your W&H product and guarantee a smooth and efficient operation.

Intended use

Surgical treatment of dental hard tissue.

Misuse can damage the surgical handpiece / contra-angle and involves risk and danger to user and third parties.

CE Production according to EU directive

0297 The surgical handpiece / contra-angle is a medical product according to the EU directive 93/42/EEC.

Skilled application

The handpiece / contra-angle is intended only for skilled application in surgery according to its purpose of use in compliance with the valid health and safety at work regulations and the valid accident prevention regulations as well as in compliance with these Instructions for use. The handpiece / contra-angle should be prepared for use and maintained by staff who have been trained in procedures for infection control, personal safety and patient safety. Improper use, (e.g. through poor hygienic maintenance), non-compliance with our instructions or the use of accessories and spare parts which are not approved by W&H, invalidates all claims under warranty and any other claims.

Service

In case of service or repair contact an authorized W&H service partner (see Page 51). Service and maintenance work must only be carried out by an authorized W&H service partner.

2. Before use – Safety notes



- > The maximum permitted torque of the drive of the WS-75 E/KM is 6 Ncm (risk of damage)!
- > The operation of the handpiece / contra-angle is permitted only on dental units which correspond to the medical device directive.
- > Always ensure the correct operating conditions and cooling function.
- > Check the handpiece / contra-angle for damage and loose parts prior to use (e.g. press-button).
- > Do not touch the soft tissue with the S-10, S-12 handpiece tip (risk of burning)!



The WS-75 E/KM contra-angle handpiece has a considerably higher level of efficiency than normal contra-angle handpieces and has been designed to fit the W&H drive units Implantmed SI-95, SI-923 / SI-915 and Elcomed SA-200 / SA-200 C.

If using a drive unit other than one for which the WS-75 E/KM has been designed, the setting for the required torque must be reduced by roughly one half, e.g.: to achieve 50 Ncm on the rotating instrument with an W&H Elcomed 100/200, the torque must be set to 30 Ncm.

The use of the contra-angle handpiece WS-75 E/KM on surgical units other than the Implantmed SI-95, SI-923 / SI-915 and Elcomed SA-200 / SA-200 C, in particular those without a calibration function, represents a risk which must be considered by the user (risk of injury). W&H explicitly advises against doing this. The user is solely responsible. No liability is accepted by W&H.

Hygienic maintenance prior to initial use

The handpiece / contra-angle is in a clean condition and sealed in PE-film when delivered. Lubricate the handpiece / contra-angle prior to initial use. Sterilize the handpiece / contra-angle, the nozzle cleaners, the Y-manifold, the spray clips and the coolant tube for internal bur cooling.

- > Oil service Page 41
- > Sterilization Page 45

3. Product description handpiece S-9, S-10, S-12

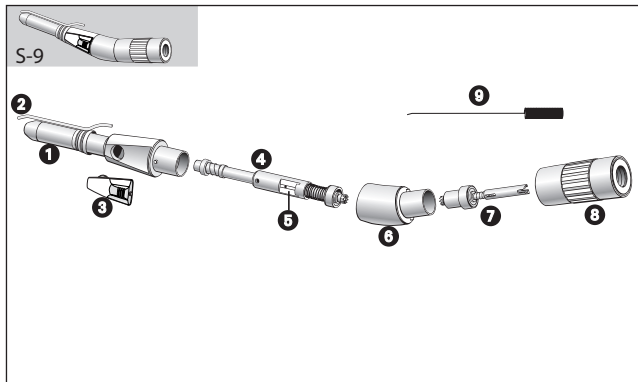

- ① handpiece head
- ② coolant tube (movable)
- ③ chuck lever
- ④ shaft
- ⑤ area of chuck lever
- ⑥ knee
- ⑦ lower shaft
- ⑧ sheath
- ⑨ long nozzle cleaner

3. Product description handpiece S-11, SL-11

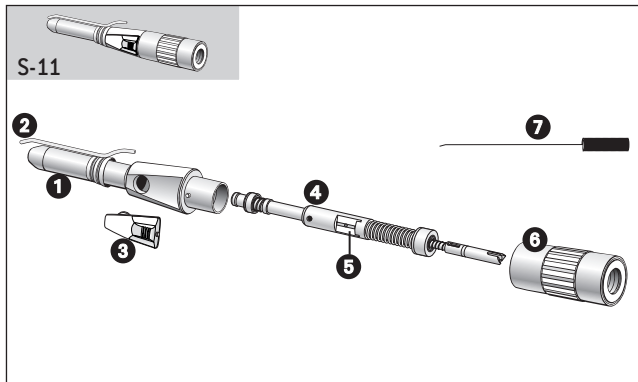

- ① handpiece head
- ② coolant tube (movable)
- ③ chuck lever
- ④ shaft
- ⑤ area of chuck lever
- ⑥ sheath
- ⑦ long nozzle cleaner

3. Product description contra-angle WS-56 E, WS-92 E/3

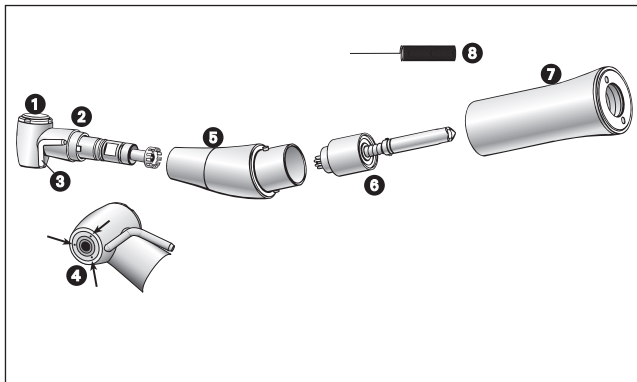

- ① press-button
- ② contra-angle head
- ③ external coolant tube
- ④ spray nozzles (only WS-92 E/3)
- ⑤ knee
- ⑥ lower shaft
- ⑦ sheath
- ⑧ short nozzle cleaner

3. Product description contra-angle WS-75 E/KM

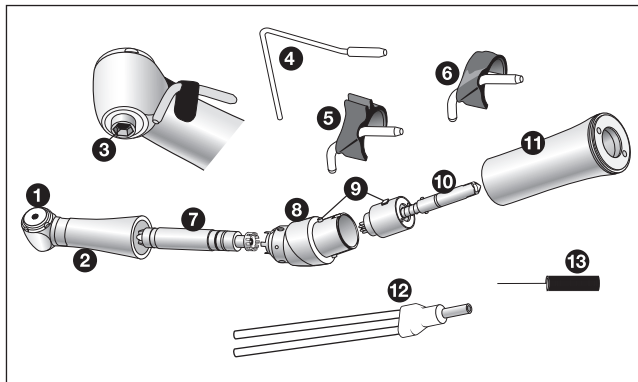

- ① press-button
- ② contra-angle head
- ③ hexagon chucking system
- ④ coolant tube for internal bur cooling (KM)
- ⑤ spray clip for KM coolant tube
- ⑥ spray clip Exco
- ⑦ middle gear
- ⑧ knee
- ⑨ hole for locking pin
- ⑩ lower shaft
- ⑪ sheath
- ⑫ Y-manifold
- ⑬ short nozzle cleaner

4. Operation – Assembly / Removal

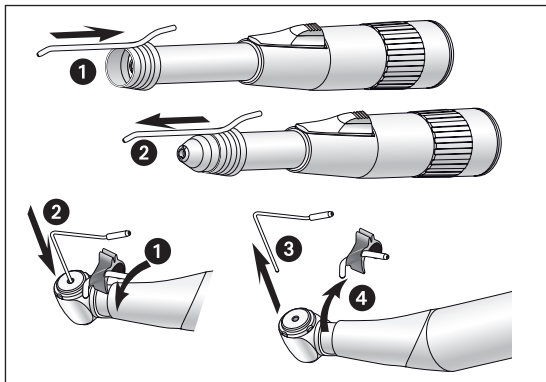

Handpiece – Coolant tube

- 1 Fit the coolant tube.
- or
- 2 Pull off the coolant tube.

Contra-angle WS-75 E/KM – Spray clip

- 1 Attach the spray clip.
- 2 Insert the coolant tube for internal bur cooling.
- or
- 3 Remove the coolant tube for internal bur cooling.
- 4 Remove the spray clip.

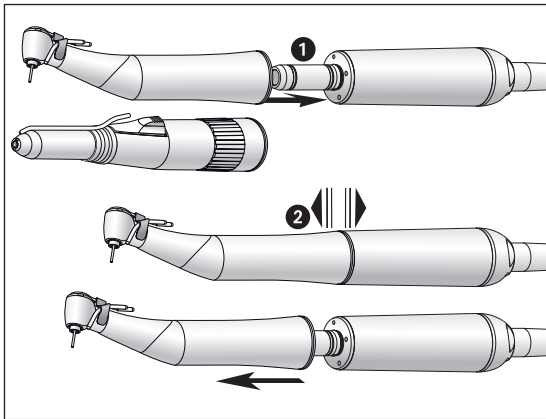

Handpiece / Contra-angle



Do not assemble / remove the handpiece / contra-angle during the operation!

- 1** Push the handpiece / contra-angle onto the motor.
> When using a locking pin between motor and instrument: see Instructions for use of the unit.
- 2** Check the secure hold on the motor.
- 3** Remove the handpiece / contra-angle from the motor by pulling in an axial direction or by pressing the release button.

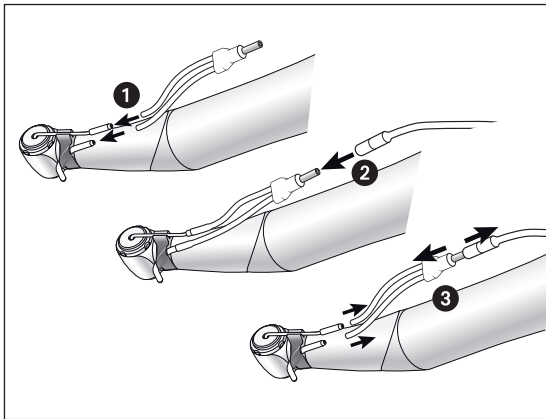

Contra-angle WS-75 E/KM – Y-manifold



Only when using the coolant tube for internal bur cooling.

- 1** Insert the coolant hose of the Y-manifold onto the coolant tube of the spray clip and onto the coolant tube for internal bur cooling.
- 2** Insert the Y-manifold into the irrigation tubing.
or
- 3** Remove the Y-manifold.



Rotary instruments

- > Use only rotary instruments which are in perfect condition and be careful when the rotary instrument is rotating. Follow the operating instructions of the manufacturer.
- > Insert rotary instruments only when the handpiece / contra-angle is stationary.
- > Do not interfere with the running or slowing down of rotary instruments.
- > Do not activate the press-button of the contra-angle or the chuck lever of the handpiece during operation. This leads to detachment of the rotary instrument and makes the head of the handpiece / contra-angle hot.

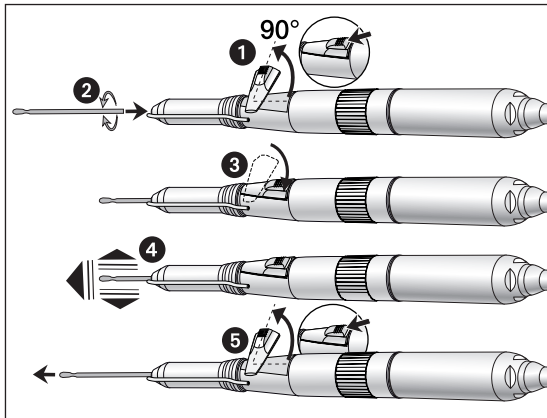

To change rotary instrument

Handpiece S-9, S-11, SL-11 (System Stryker)

- 1 Unlock and swivel the chuck lever.
- 2 Insert rotary instrument until back stop and turn until the locking pin engages.
- 3 Return the chuck lever to the initial position.
- 4 Check secure location by applying slight axial tension.
- 5 Unlock and swivel the chuck lever. Remove the rotary instrument.

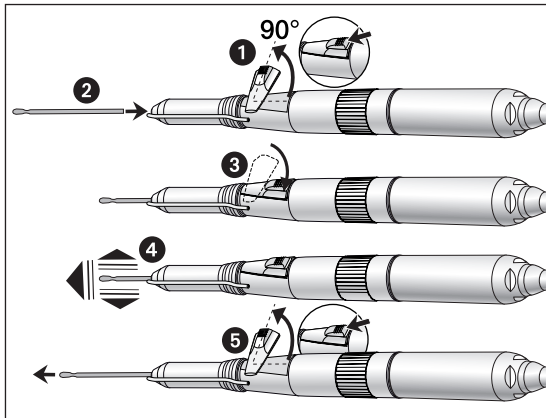

Handpiece S-10, S-12

- 1** Unlock and swivel the chuck lever.
- 2** Insert rotary instrument until back stop.
- 3** Return the chuck lever to the initial position.
- 4** Check secure location by applying slight axial tension.
- 5** Unlock and swivel the chuck lever. Remove the rotary instrument.

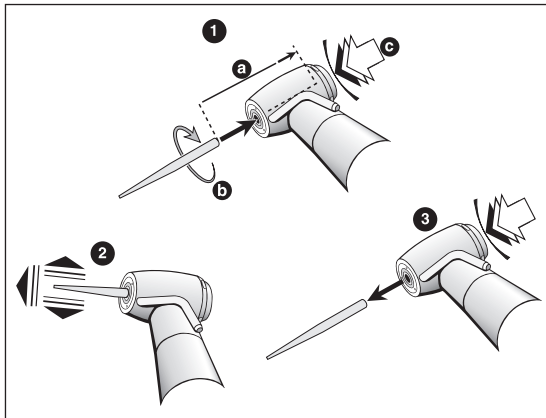

To change rotary instrument

Contra-angle WS-56 E, rotary instrument \varnothing 2.35 mm

- 1** Insert the rotary instrument until back stop [a] and turn the rotary instrument until it engages [b].

Contra-angle WS-92 E/3, rotary instrument \varnothing 1.6 mm

- 2** Insert the rotary instrument. Activate press-button [c], at the same time insert the rotary instrument until back stop [a].
- 3** Check secure location by applying slight axial tension.
- 4** Remove the rotary instrument by pushing the press-button.

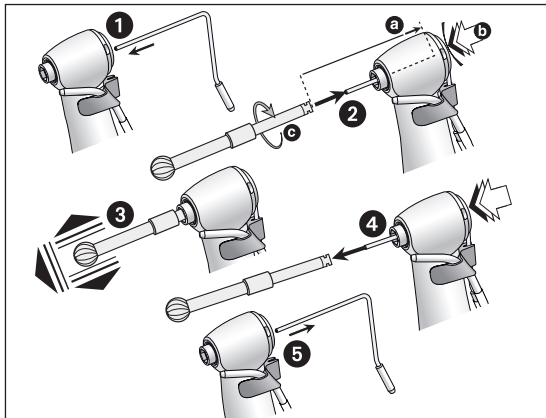

Contra-angle WS-75 E/KM

> using internal bur cooling,
rotary instrument \varnothing 2.35 mm

- 1 Insert the coolant tube for internal bur cooling.
- 2 Insert the rotary instrument over the coolant tube until back stop [a]. Activate press-button [b] and turn the rotary instrument until it engages [c].
- 3 Check secure location by applying slight axial tension.
- 4 Remove the rotary instrument by pushing the press-button.
- 5 Remove the coolant tube for internal bur cooling.

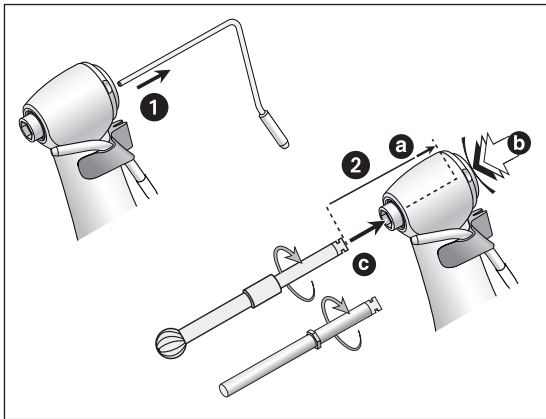

Contra-angle WS-75 E/KM

- > *without using internal bur cooling, rotary instrument \varnothing 2.35 mm*
- > *with hexagon, rotary instrument \varnothing 2.35 mm*

- 1** Remove the coolant tube for internal bur cooling.
- 2** Insert the rotary instrument until back stop [a]. Activate press-button [b] and turn the rotary instrument until it engages [c].

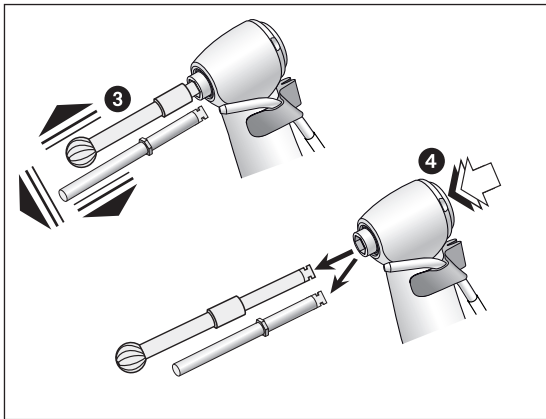

- ③ Check secure location by applying slight axial tension.
- ④ Remove the rotary instrument by pushing the press-button.



Ask your implant supplier for an applicable rotary instrument with hexagon.

Test run

- > Insert the rotary instrument.
- > Start the handpiece / contra-angle.
- > If you observe problems (e.g. vibrations, unusual noise, overheating, coolant supply failure or leakage), **stop the handpiece / contra-angle immediately** and contact an authorized W&H service partner (see Page 51).

5. Hygienic maintenance



- Follow your country-specific directives, standards and guidelines for cleaning, disinfection and sterilization.
- > You can process the handpiece / contra-angle manually or mechanically.



- > Wear protective clothing.
 - > Remove the handpiece / contra-angle from the motor.
 - > Remove the rotary instrument.
-
- > Clean and disinfect the handpiece / contra-angle **immediately after every treatment**, to flush out any liquid (such as blood, saliva etc.) and to prevent settling on the internal parts.



> Reassemble the handpiece / contra-angle following manual cleaning and disinfection (serial numbers on individual parts must be identical).



> Sterilize the reassembled handpiece / contra-angle following manual or mechanical cleaning, disinfection and lubrication.

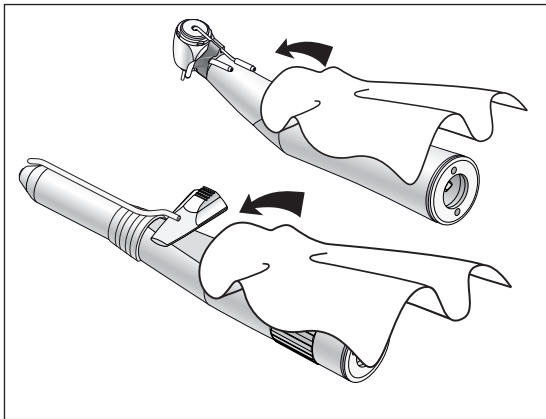

Pre-disinfection

> If heavily soiled: Clean first with disinfectant cloths.



Only use disinfectants that have no protein-fixing effects.

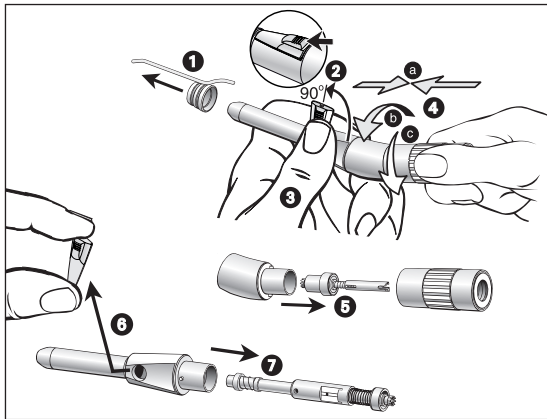

Disassemble handpiece

S-9, S-10, S-12

- ① Pull off the coolant tube.
- ② Unlock and swivel the chuck lever.
- ③ Hold with one hand the handpiece head and with the thumb the chuck lever.
- ④ Press the sheath firmly against the knee [a]. At the same time turn off the knee from the sheath by turning twice [b], [c].
- ⑤ Remove the lower shaft from the knee.
- ⑥ Pull off the shaft until back stop and remove the chuck lever.
- ⑦ Remove the shaft from the handpiece head.

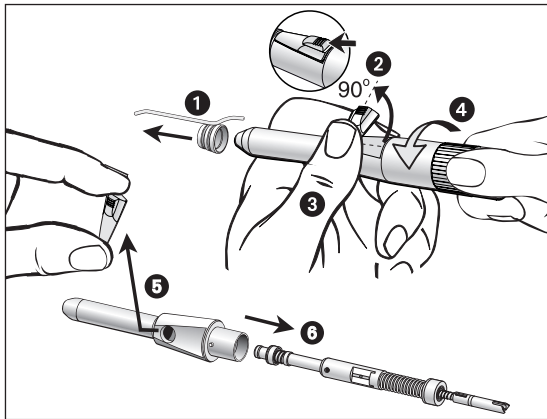

S-11, SL-11

- 1 Pull off the coolant tube.
- 2 Unlock and swivel the chuck lever.
- 3 Hold with one hand the handpiece head and with the thumb the chuck lever.
- 4 Turn off the sheath from the handpiece head by turning once.
- 5 Pull off the shaft until back stop and remove the chuck lever.
- 6 Remove the shaft from the handpiece head.

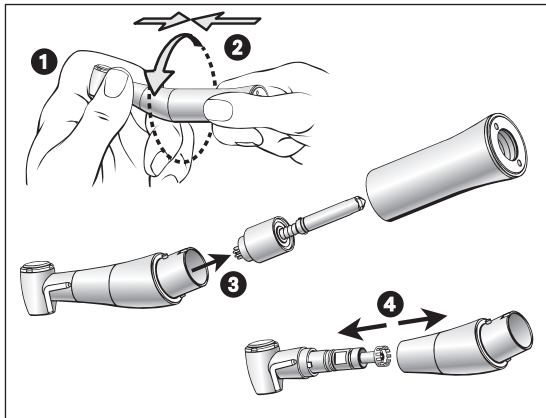

Disassemble contra-angle

WS-56 E, WS-92 E/3

- 1 Hold the contra-angle head firmly with one hand.
- 2 Press sheath gently against knee. At the same time turn off the sheath from the knee.
- 3 Remove the lower shaft.
- 4 Remove the contra-angle head from the knee.

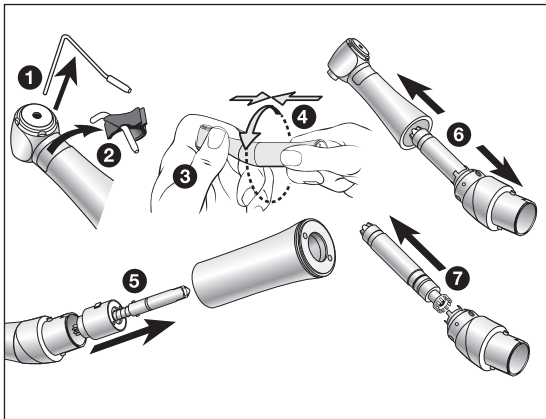

WS-75 E/KM

- 1 Remove the coolant tube for internal bur cooling.
- 2 Remove the spray clip.
- 3 Hold the contra-angle head firmly with one hand.
- 4 Press sheath gently against knee. At the same time turn off the sheath from the knee.
- 5 Remove the lower shaft.
- 6 Remove the knee.
- 7 Remove the middle gear from the knee.

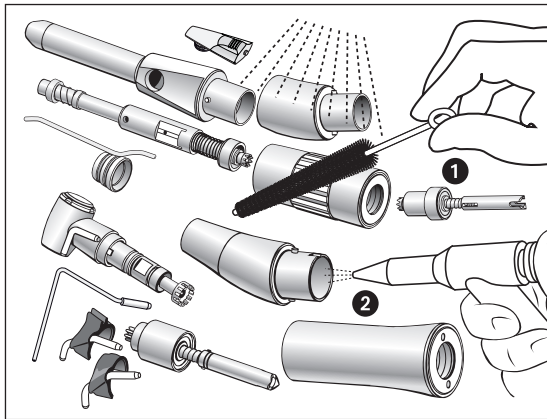

Manual cleaning internal and external

- 1 Rinse under demineralized water ($< 38\text{ }^{\circ}\text{C}$ / $< 100\text{ }^{\circ}\text{F}$) with the aid of a brush (brush is not recommended in U.K.).
- 2 Remove any liquid residues (absorbent cloth, blow dry with compressed air).



Do not place the handpiece / contra-angle in liquid disinfectant or in an ultrasonic bath.

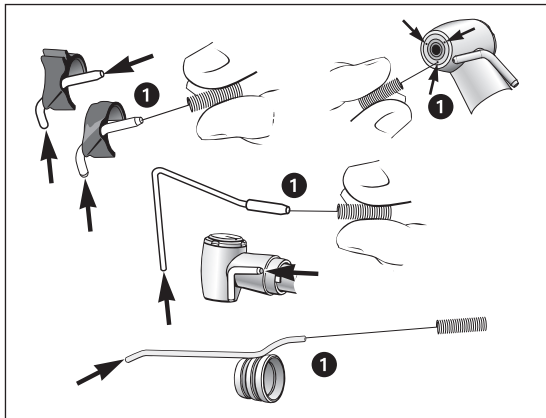

Cleaning of the external coolant tubes

Cleaning of the spray nozzles – only WS-92 E/3



Removable coolant tubes, spray clips and nozzle cleaners can be cleaned in an ultrasonic bath.

- 1 Clean coolant outlets carefully with the nozzle cleaner to remove dirt and deposits.

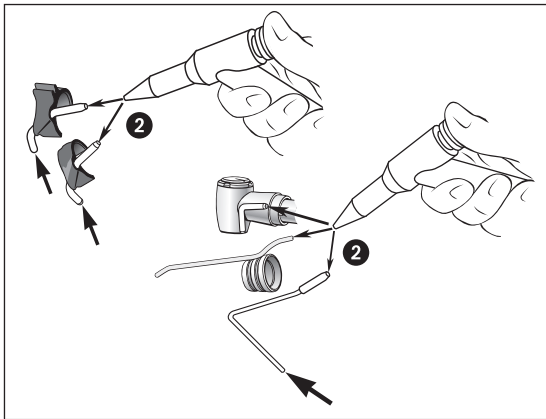

- 2** Blow through the coolant tube and coolant outlets with the air syringe.

 In the case of clogged up coolant outlets or coolant tubes contact an authorized W&H service partner (see Page 51).

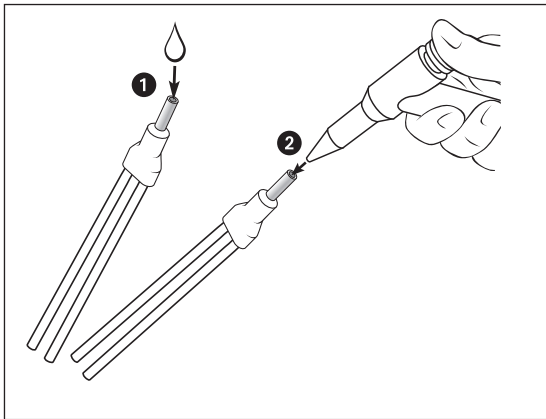

Contra-angle WS-75 E/KM Cleaning of the Y-manifold



The Y-manifold can be cleaned in an ultrasonic bath and / or in a thermo washer disinfectant.

- ➊ Rinse with demineralized water (< 38 °C / < 100 °F).
- ➋ Remove any liquid residues using compressed air.

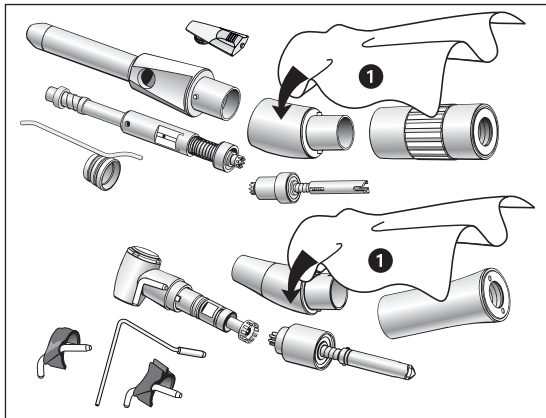

Manual disinfection

- > Disinfection with disinfectants,
① wiping disinfection is recommended.
- > Use only disinfectants which do not contain chlorine and which are certified by officially recognized institutes. **For USA and Canada:** Use EPA registered surface disinfectants.
- > Note the manufacturer's specifications for the use of the disinfectants.



After manual cleaning, disinfection and lubrication you must carry out a final sterilization (wrapped) in the class B or S steam sterilizer according to EN 13060.

For USA and Canada: Hospital grade sterilization with pre and post vacuum cycle.

Mechanical cleaning and disinfection internal and external



The handpiece / contra-angle can be cleaned and disinfected in a thermo washer disinfectant.



W&H recommends processing with thermo washer disinfectant.

> Note the manufacturer's specifications on equipment, cleaning agents and detergents.



> Make sure, that the handpiece / contra-angle is completely dry internally and externally after thermo washer disinfection. Remove any liquid residues with compressed air.

> Lubricate the dry handpiece / contra-angle immediately after thermo washer disinfection.

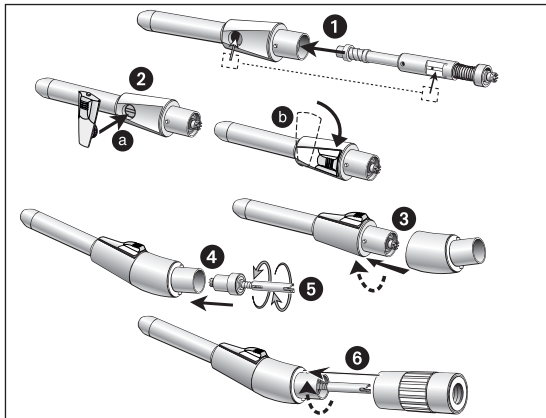

Reassemble handpiece

S-9, S-10, S-12

- 1 Insert shaft into the handpiece head and position area of chuck lever.
- 2 Insert chuck lever (a) and turn it to initial position (b).
- 3 Position the knee into the handpiece head and turn until it engages (2 positions are possible).
- 4 Insert lower shaft into the knee.
- 5 Check free running of the lower shaft.
- 6 Position sheath onto the knee and turn until it engages.

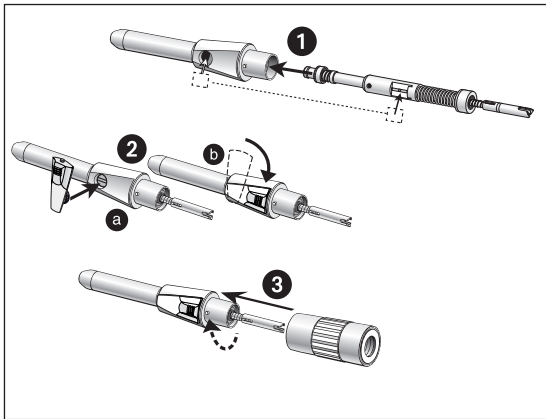

S-11, SL-11

- ➊ Insert shaft into the handpiece head and position area of chuck lever.
- ➋ Insert chuck lever (a) and turn it to initial position (b).
- ➌ Insert the sheath onto the handpiece head and turn until it engages.

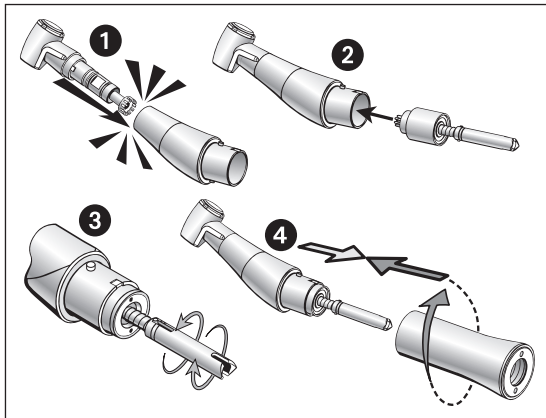

Reassemble contra-angle

WS-56 E, WS-92 E/3

- ① Insert contra-angle head into the knee until it engages (4 positions are possible).
- ② Insert the lower shaft into the knee.
- ③ Check free running of the lower shaft.
- ④ Press the sheath firmly against the knee and turn until it engages.

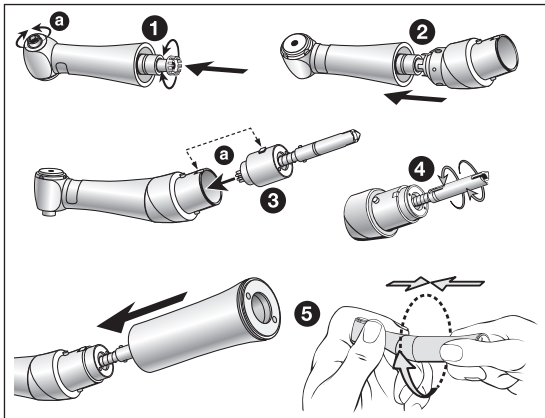

WS-75 E/KM

- 1 Insert the middle gear into the contra-angle head. Check free running of the chucking system [a].
- 2 Insert the knee onto the contra-angle head until it engages [4 positions are possible].
- 3 Insert the lower shaft into the knee and mind the position of the hole for locking pin [a].
- 4 Check free running of the lower shaft.
- 5 Press the sheath firmly against the knee and turn until it engages.

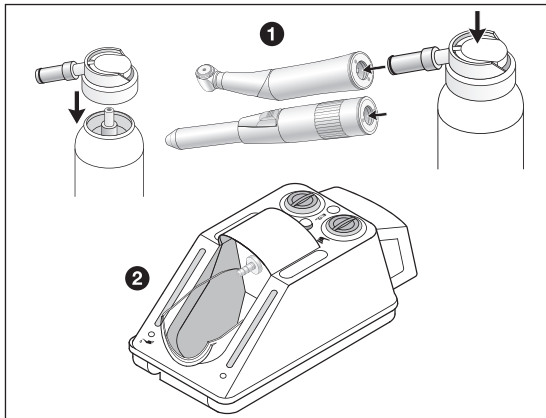

Daily oil service

- ❶ **Only with W&H Service Oil F1, MD-400**
 - > Follow the Instructions for use of the oil spray can.
- or
- ❷ **Only with W&H Assistina**
 - > See Instructions for use of Assistina.

Recommended lubrication cycles

- > Essential after every internal cleaning
 - > Before each sterilization
- or
- > After 30 minutes of use or at least once daily

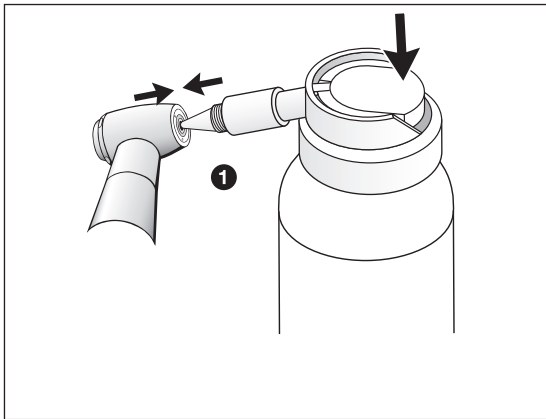

Contra-angle WS-92 E/3

Weekly oil service of the chucking system

- ➊ Only with W&H Service Oil F1, MD-400
 - > Fit the spray cap REF 02036100 on the spray can.
 - > Hold the contra-angle firmly.
 - > Press the tip of the spray nozzle firmly into the chucking system.
 - > Spray for approx. 1 second.

or

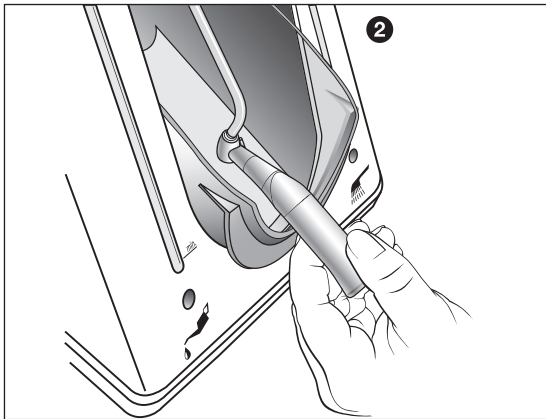

2 Only with W&H Assistina

- > Fit the adaptor REF 02693000 onto the maintenance attachment. Direct exit nozzle downwards.
- > Press the bur side of the contra-angle onto the adaptor from below.
- > Start the Assistina.
- > Press the contra-angle onto the adaptor for approx. 10 seconds.
- > Remove the contra-angle from the adaptor.
- > Close the cover of the Assistina and allow it to run for the remainder of the maintenance cycle [approx. 25 seconds].

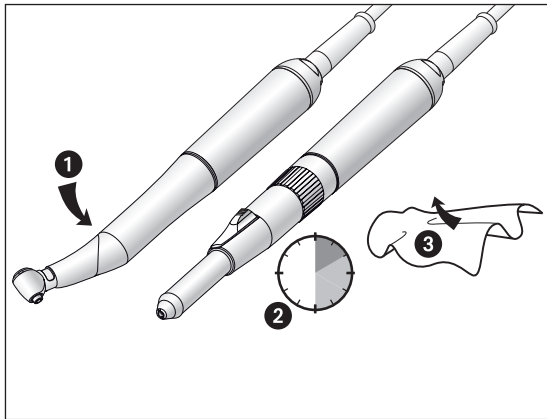

Test run following oil service

- ➊ Place the handpiece with the instrument tip, the contra-angle with the head, downwards.
- ➋ Start the handpiece / contra-angle for 30 seconds to remove excessive oil. Start at the minimum speed and increase to the maximum speed within 5 to 10 seconds.
 - > Repeat the complete hygiene and maintenance process at any sign of dirt re-emerging.
- ➌ Wipe the handpiece / contra-angle with gauze or soft cloth.

Sterilization and storage



W&H recommends sterilization according to EN 13060, class B.

For USA and Canada: Hospital grade sterilization with pre and post vacuum cycle.

- > Note the instructions of the unit manufacturer.
- > Clean, disinfect and lubricate before sterilizing.
- > Wrap the handpiece / contra-angle and the accessory in sterile goods packing according to EN 868-5.
For USA and Canada: Place the handpiece / contra-angle and the accessory in a standard handpiece sterilization pouch.
- > Make sure, that you only remove dry sterile goods.
- > Store sterile goods dust-free and dry.

Y-manifold



W&H recommends that the Y-manifold is replaced after 50 sterilization cycles.

Approved sterilization procedures



Follow your country-specific directives, standards and guidelines.

- > Steam sterilization class B (pre and post vacuum) with sterilizers in accordance with EN 13060. Sterilization holding time a minimum of 3 minutes at 134 °C (273 °F). Required pressure -0.85 bar [-12.3 psi] up to 2.16 bar [31.3 psi].

or

- > Steam sterilization class S with sterilizers in accordance with EN 13060. The sterilizer manufacturer must give their express approval for the sterilization of handpieces / contra-angles. Sterilization holding time a minimum of 3 minutes at 134 °C (273 °F).

For USA and Canada

- > Steam vacuum sterilization (hospital grade sterilization), 4 minutes at 134 ±2 °C (273 ±4 °F) or
- > Gravity displacement sterilization, 6 minutes at 134 ±2 °C (273 ±4 °F)
- > All other sterilization methods are not approved and must not be used.

6. W&H Accessories

Use only original W&H accessories and spare parts!

Suppliers: W&H partners

301	W&H Assistina
02693000	Assistina adaptor for chucking system
10940021	W&H Service Oil F1, MD-400 (6 pcs)
02036100	spray cap with nozzle for chucking system
02038200	spray cap with nozzle for handpieces / contra-angles
00636901	long nozzle cleaner for handpieces
02015101	short nozzle cleaner for contra-angles
06016400	Y-manifold (3 pcs)
02610500	coolant tube for internal bur cooling (KM)
04757100	spray clip for KM coolant tube (3 pcs)
05051000	spray clip Exco

7. Technical data

Surgical handpieces	S-10	S-9 / S-11	SL-11	S-12
Transmission ratio	1:1	1:1	1:1	1:2
Colour coding	blue	blue	blue	orange
Motor coupling according to standard	ISO 3964	ISO 3964	ISO 3964	ISO 3964
Rotary instruments EN ISO 1797-1 (\emptyset mm)	2.35	2.35	2.35	2.35
Length approved by W&H (mm)	max. 70* ^o	max. 45* ^o	max. 45* ^o	max. 70*
Minimum chucking length (mm)	until back stop	until back stop	until back stop	until back stop
Maximum rated speed (min^{-1})	50,000	50,000	30,000	40,000
Spray water volume ISO 7785-2 (ml/min)	> 50	> 50	> 50	> 50

- * When using longer rotary instruments the user must ensure by correct selection of the operating conditions, that there is no danger to the user, patient or third parties.
- ^o System Stryker usable

7. Technical data

Surgical contra-angle handpieces		WS-56 E	WS-75 E/KM	WS-92 E/3
Transmission ratio		1:1	20:1	1:2,7
Colour coding		blue	green	orange
Motor coupling according to standard		ISO 3964	ISO 3964	ISO 3964
Rotary instruments	EN ISO 1797-1 (\emptyset mm)	2.35	2.35*	1.6
Length approved by W&H	(mm)	max. 34**	max. 45**	max. 25**
Minimum chucking length	(mm)	engaging	engaging	until back stop
Maximum rated speed	(min^{-1})	50,000	50,000	50,000
Spray water volume	ISO 7785-2 (ml/min)	> 50	> 50	> 50
Maximum torque at rotary instrument	(Ncm)	–	70*	–
Using rotary instrument with hexagon	(Ncm)	–	105*	–

* When having a torque higher than 30 Ncm on the rotary instrument you have to use hardened shafts (>50 HRC, >520 HV) [risk of deformation].

** When using longer rotary instruments the user must ensure by correct selection of the operating conditions, that there is no danger to the user, patient or third parties.

Letter of indemnity

This W&H product has been manufactured with great care by highly qualified specialists. A wide variety of tests and controls guarantee faultless operation. Please note that claims under warranty can only be validated when all the directions in the instructions for use have been followed.

As manufacturer, W&H is liable for material or manufacturing defects within a warranty period of 12 months from the date of purchase.

We accept no responsibility for damage caused by incorrect handling or by repairs carried out by third parties not authorized to do so by W&H!

Claims under warranty – accompanied by proof of purchase – must be sent to the vendor or to an authorized W&H service partner. The provision of service under warranty extends neither the warranty period nor any other guarantee period.

12 months warranty

Authorized W&H service partner

Find your nearest W&H service partner at <http://wh.com>

Simply go to the menu option »Service« for full details. Alternatively please contact:

W&H (UK) LIMITED, 6 Stroud Wood Business Centre, Park Street, St Albans, Herts AL2 2NJ, United Kingdom
t + 44 1727 874990, f + 44 1727 874628, E-Mail: technical.uk@wh.com

W&H Impex Inc., 6490 Hawthorne Drive, Windsor, Ontario, N8T 1J9, Canada
t + 1 800 2656277, + 1 519 9446739, f + 1 519 9746121, E-Mail: service.ca@wh.com

W&H Impex Inc., 14300 Henn Rd., Dearborn, MI 48126, USA
t + 1 800 2656277, + 1 519 9446739, f + 1 519 9746121, E-Mail: service.us@wh.com

W&H Austria GmbH, Ignaz-Glaser-Straße 53, 5111 Bürmoos, Austria
t + 43 6274 6236-239, f + 43 6274 6236-890, E-Mail: office.at@wh.com

A-DEC AUSTRALIA CO. INC., Unit 8, 5-9 Ricketty Street, Mascot NWS 2020, Australia
t + 61 2 83324000, f + 61 2 83324099, E-Mail: a-dec@a-dec.com.au

Manufacturer

W&H Dentalwerk Bürmoos GmbH

Ignaz-Glaser-Straße 53, 5111 Bürmoos, Austria

t + 43 6274 6236-0,

office@wh.com

f + 43 6274 6236-55

wh.com

Form-Nr. 50559 AEN

Rev. 009 / 02.04.2015

Subject to alterations

